

AT A GLANCE

FEATURES

- Neutral safety switch (ensures engine can only be started when engine is in neutral)
- Universal cable fitting suitable for 33C, 33C supreme, OMC and Mercury cables
- Adjustable throttle damper - prevents throttle creep due to heavy throttle return bias, especially evident in some diesel engines
- Standard control suits 33C type cables
- Neutral "warm up" button for throttle only operation

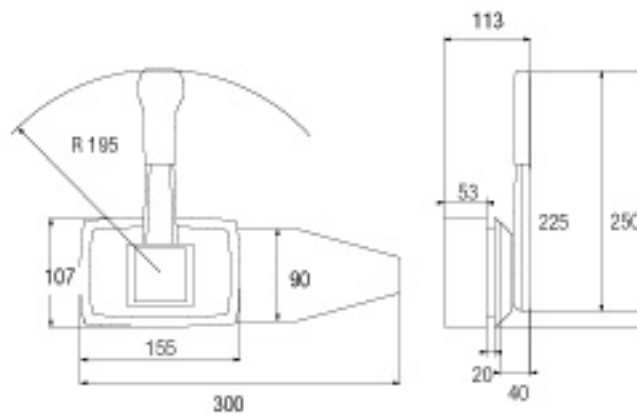

MNS SAIL BOAT TOP MOUNT CONTROL

TECHNICAL DATA

Dual function, single lever for all types of single engine applications designed for sail boat use.

Simple streamline control handle design ensures no snagging of ropes.

Suits 33C type control cables.

ORDER INFORMATION	PART NO.
MNS SB	314495-111

